

Roller Flex Bollard



Sometimes the best defense is rolling with it.

Distributing impact energy with rock and spin capabilities, the Roller Flex Bollard protects against glancing blows—perfect for high-traffic corners. Engineered to install fast and require no maintenance, it keeps your business rolling right along.

Rotating HDPE Shell Exclusive design rocks, rolls and lifts when hit

Flexible Core Absorbs direct impacts, preventing damage to your facility

Zero Maintenance Install it once, get peace of mind for years

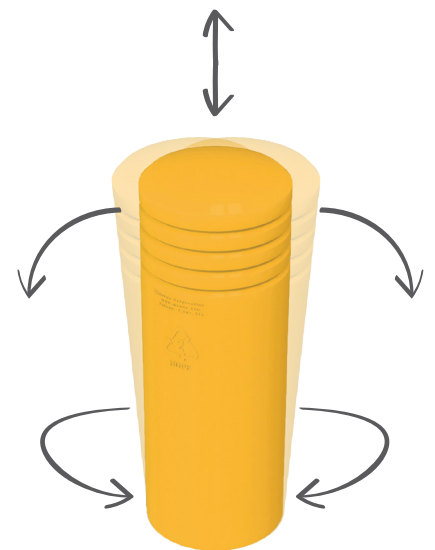

Roller Flex Bollard

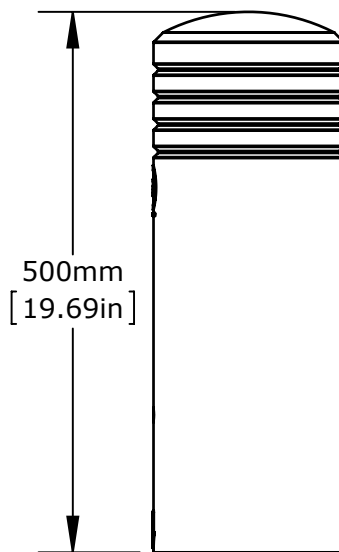
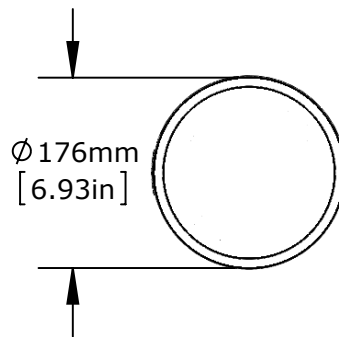
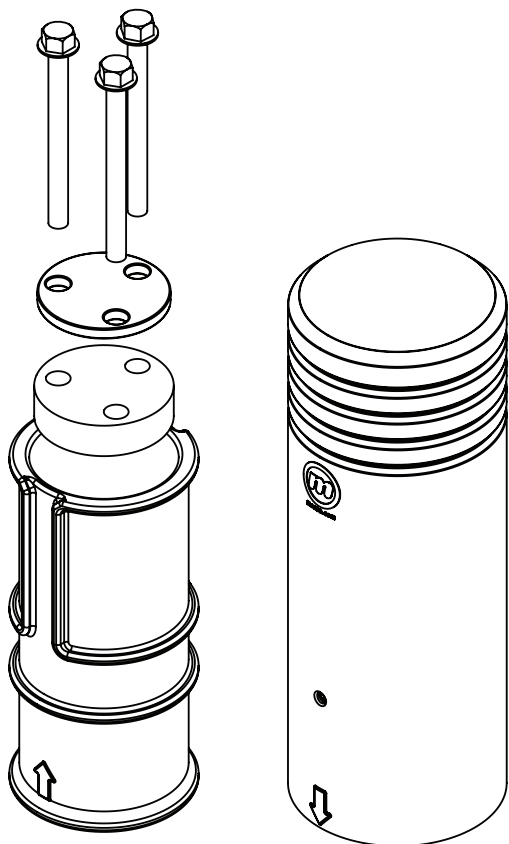

Roller Flex Post Materials

HDPE shell, iron core, rubber damper, anchor kit



Guides your equipment around high traffic corners to avoid damage.

The Roller Flex Post can withstand an impact of 10,734 lb [477 kN].



This is equivalent to a 9,000 lb [4082.33 kg] vehicle at 3.4 mph [5.5 km/h] and recover to the original position.

Report #444504-8 | For more information go to mccue.com



McCue Corporation
Peabody, MA 01960, USA
+1 (800) 800 8503
customer care@mccue.com

McCue UK & Europe
Milton Keynes, United Kingdom
+44 (0)1908 365 511
uksales@mccue.com

McCue Asia
迈客(厦门)有限公司
Xiamen, Fujian, China
+86-592-2200790

mccue.com

